

2 loops control unit



TFA4-1192



4-loops addressable fire alarm panel managing up to 1192 devices via the loops - Proprietary protocol Fire-Speed - True color TFT display 482 x 272 pixel - Integrated speaker with volume setting - Programmable local or master/slave functioning mode - Max. 16 repeater panels with 7" TFT display - 2 RS485 serial buses (master and slave) - 10 outputs - 300 zones programmable as fire detection or technical zone - 100 virtual zones to be used as operation category for the Boolean functions - 400 Boolean functions - 200 alarm plans to be associated to the zones - 32 time periods to be used as operation category - 5A switching power supply Fly-back type - USB port - Serial port - Ethernet hub - Internet protocols Tecnoalarm, Contact-ID, SIA - Integrated RSC® technology: programming and monitoring via LAN/WAN, Hardware Coherence Control, Parametric Analysis and Device Monitor tools and relative reports - Aluminum/steel casing - Dimensions (L x H x D) 441 x 347 x 149mm - IP30 - Bay for 2x 12V/12Ah batteries (not included)
EN 54-2:1997 + A1:2006 - **EN 54-4:**1997 + A2:2006 - Certification number 0051-CPR-0388

Item no. TF1TFA41192-UK

OVERVIEW

The addressable fire alarm control unit TFA4-1192 is designed and built in compliance with the standards EN 54-2-A1:2006 (main unit) and EN 54-4-A2:2006 (supply section).
 The design was implemented as part of a ISO9001 quality management system that involves the application of a set of rules for project planning and plans all subsequent test and control activities necessary for the production of all the items that make up the above control units.
 All the components of the equipment were selected for the intended purposes. Their specifications are met when the environmental conditions outside the enclosure correspond to those specified for the class 3K5 of standard EN 60721-3-3:1995.
 Indoor use: the control unit should be installed in a location protected from the inclemency of the weather. Temperature and humidity control is not required in the installation environments.

PHYSICAL STRUCTURE

Addressable fire alarm control unit, constituted by a modular structure composed of:

- Metal cabinet which can hold two 12V-12Ah batteries.
- CPU controller card that integrates the user interface consisting of display, and management and programming keyboard.
- Connection card on which the connection infrastructures of detection loops, system bus, outputs and Ethernet node are located.
- Fly-back switching power supply 24V - 5A (ALSW285PFC)

LOGICAL STRUCTURE

300 logic detection zones freely customizable as Fire or technological zones. Automatic management of the Default Zone. 100 virtual logical Zones, freely assembled, which can be subjected to Boolean Formulas for functional conditioning of the system.

Centrale 2 Loop



A	Notification Led area	B	Display	C	Management key area
D	Numeric keys area				

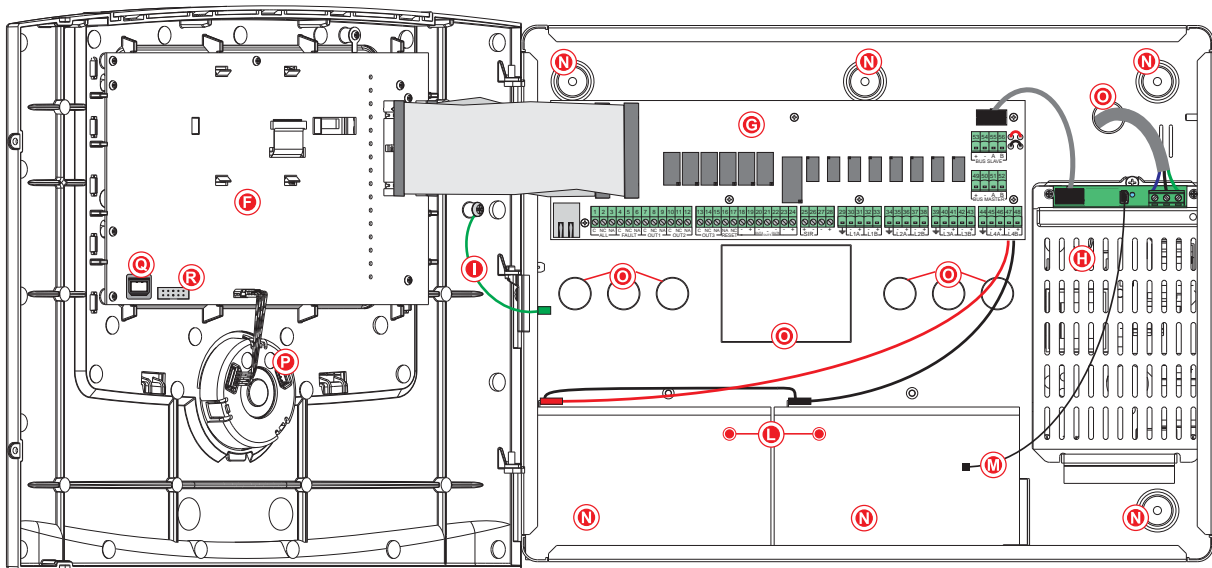

F	CPU card	L	Battery 12V 12Ah	P	Internal speaker
G	Connection board	M	NTC probe for battery temperature monitoring	Q	USB Port
H	ALSW285PFC power supply	N	Wall mount holes	R	TTL serial interface
I	Ground Connection	O	Cable entry		

DETECTION LOOPS

Each detection loop can manage 199 sensors and 99 modules. The programming of the devices connected on the LOOP is facilitated by the self-learning function. Device polling speed with full load Loop of less than 1 sec. For privileged devices, it is possible to set a higher frequency.

SIGNALLING OUTPUTS

The control unit is equipped with dedicated mandatory signalling outputs: Alarm, Siren, Fault and Reset and with freely programmable signalling outputs: 3 relay outputs and 3 open collectors outputs.

SYSTEM CONFIGURATION

The control unit can be programmed in Local, Master or Slave mode. Local mode allows to realize a simple system consisting of a single control unit. The Master and Slave modes allow to create complex systems, consisting of multiple control units. These systems include a Master control unit which can control up to 15 Slave control units.

AUTOMATED CONTROLS

The system automatically performs functions based on the programming of: System timers, 4-year calendar, 32 time ranges, 400 Boolean formulas.

2 loops control unit

USER INTERFACE

Multi-purpose user interface consisting of: colour graphic display, 16 signalling LEDs, extended programming and management system keyboard, speech synthesis with customizable dictionary and speaker dedicated to sound alerts.

The intensity of the sound alerts can be programmed, alerts modes depend on the signalled events.

The graphic display of the control unit uses a clear iconography, the information is displayed in hierarchical order. The use of colours and the variable size of the fonts highlight the alerts according to their relevance. The exposure of the alarm information structured on multiple levels of detail, enables a rapid classification and a clear identification of the source of the alarm, in cases of obvious danger, data is integrated in the display of the alarm plan related to the event.

ACCESS LEVELS

Access to basic functions and system programming regulated by passwords which control the access levels to the system. The control unit recognizes 4 access levels. The first access level is not subject to access password, it enables to acknowledge the alarm and examine the associated detail information.

The access levels 2-User, 3-Installer and 4-Manufacturer, are regulated by password and provide access, in accordance with the different skills, to functional information and programming of the system.

ETHERNET HUB

The Ethernet connections are managed by the integrated 10 Mbit to 100 Mbit standard 803.2 half/full duplex Ethernet interface.

The interface uses four communication channels dedicated to specific functions:

- Channel 1 - LOCAL SERVER TECNOALARM
Server channel for LAN connection
- Channel 2 - REMOTE SERVER TECNOALARM
Server channel for WAN or VPN connection
- Channel 3 - TECNOSERVER TECNOALARM
Client channel for the notification of events using 8 channels. Each channel notifies the programmed IP address of the events. The communication is built using the protocol associated to the channel.
- Channel 4 - CALL BACK TECNOALARM
Client channel for call back and test call communications

The communication channels support 128 bit AES encryption.

Access to the Server channels is governed by a White list. A programmable test call function is available.

MANAGEMENT SOFTWARE

The system can be fully managed, locally or remotely, by software modules that allow programming and management through LAN or WAN connection.

MONITORED SYSTEM MODE

The fire alarm system provides a "Monitored System" mode, which can be operated on condition that the system is under the direct control of authorized personnel. The activation and deactivation of this operating mode is subject to the recognition of a level 2 password. Functioning of the Monitored System mode can be limited by time periods, so that the operating mode can only be activated during the programmed period of time and is deactivated automatically on expiry of it. In the Monitored System mode, the system has a different mode of reporting alarm events.

RSC® FUNCTIONS

The RSC® functions allow to program, monitor and remotely control the system locally or remotely. With the RSC® functions you can perform the following tasks:

- Hardware consistency check: the check analyses and records the operating parameters and the hardware and software identification data for all devices. The collected data is correlated with the programming data of the system.
- Parametric analysis: the data recorded by the hardware consistency function is used as comparison data for subsequent parametric analyses, with this analysis, all possible deviations from the values previously recorded are detected and reported.
- Device monitor: the function allows to select a single device of the System to perform a dynamic real-time monitoring of all the operating parameters of the device.

SYSTEM REPORTS

The RSC® functions allow to automatically obtain a number of report files that can be printed or stored. The reports are very useful, with them it is possible to officially document the following data:

- Programming Report: the report includes all the programming data of all the devices that make up the system.
- Hardware consistency report: the report contains all the functional and identification data of all the devices that make up the system.
- Parametric analysis report: the report collects and compares each time the functional data of the devices that make up the system, highlighting the deviations and the drifts of the values recorded and certified in the previous parametric analyses.
- Event Log Report: the report shows the event data stored by the control unit.

The events can be filtered by date and/or event type.

System Configuration

	Max. system configuration TFA4-1192
EXPANSIONS	16
LOOPS	4
DETECTORS PER LOOP	199
TOTAL DETECTORS	796 (199 x 2)
MODULES PER LOOP	99
TOTAL MODULES	396 (99 x 2)

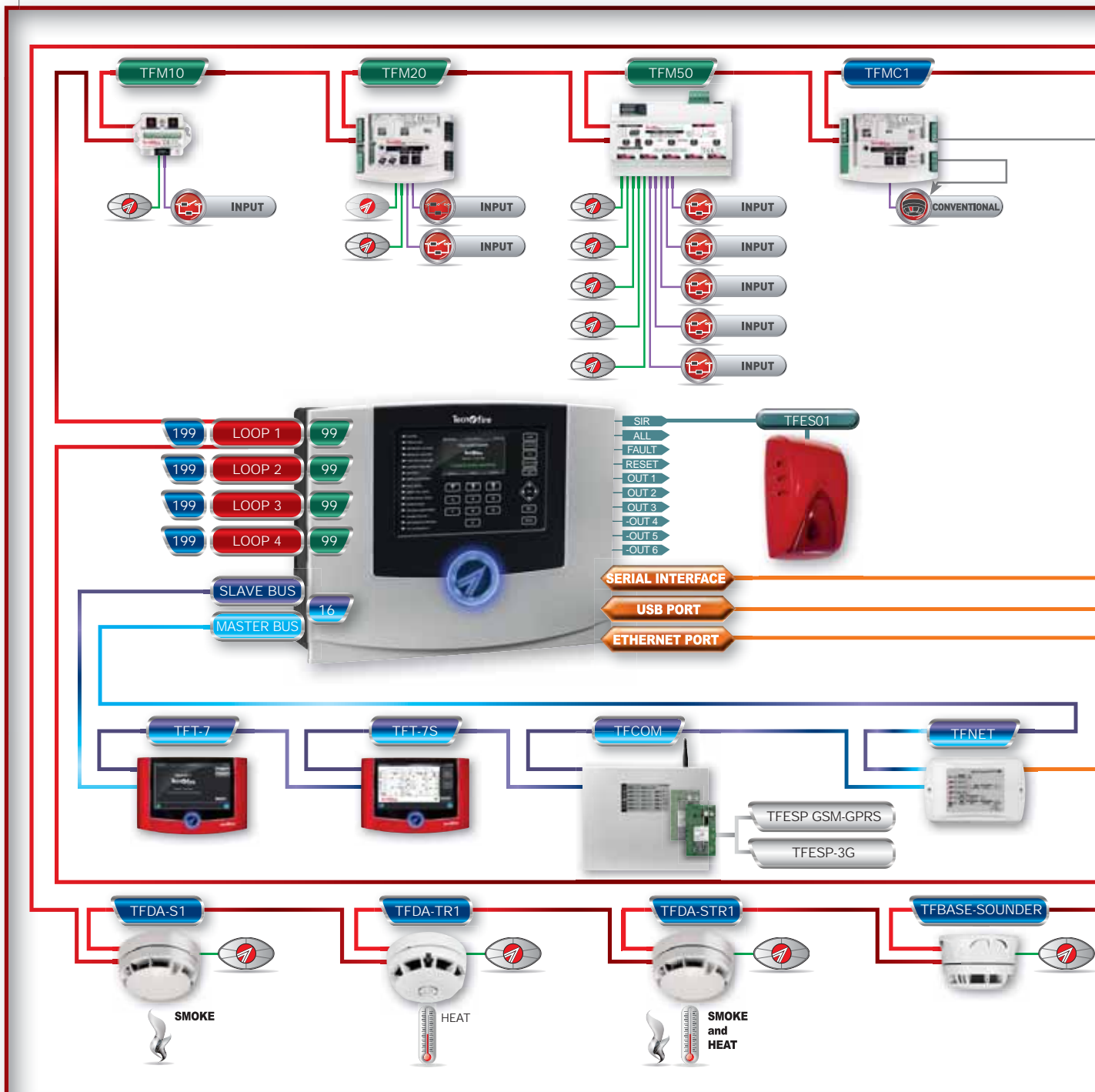

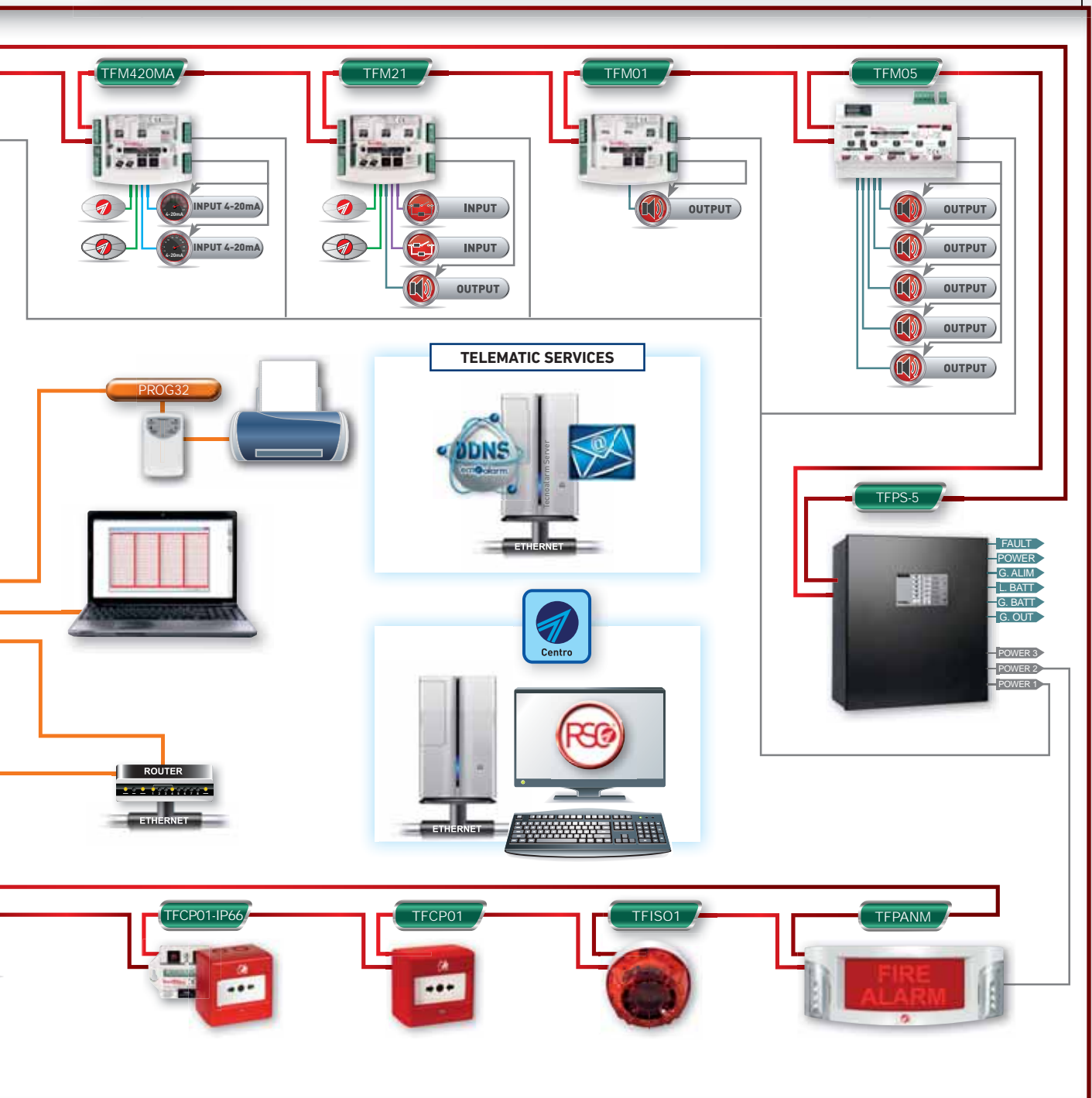

Centrali indirizzate - Addressable fire alarm panels - Systèmes d'alarme incendie adressables - Sistemas de incendio direccionables

Network Configuration

	MAX. SYSTEM CONFIGURATION TFA2-596	MAX. SYSTEM CONFIGURATION TFA4-1192	MAX. NETWORK CONFIGURATION TFA4-1192
EXPANSIONS	16	16	256 (16 x 16)
LOOPS	2	4	64 (4 x 16)
DETECTORS PER LOOP	199	199	
TOTAL DETECTORS	398 (199 x 2)	796 (199 x 4)*	12736 (796 x 16)*
MODULES PER LOOP	99	99	
TOTAL MODULES	198 (99 x 2)	396 (99 x 4)	6336 (396 x 16)
ZONES	300	300	4800 (300 x 16)
VIRTUAL ZONES	100	100	1600 (100 x 16)

* The EN 54-2 standard allows to connect 512 detectors and/or manual call points to one single fire alarm panel.
Therefore, the maximum number of detectors managed by a Tecnofire network is 8,192 (512 devices multiplied by 16 fire alarm panels).

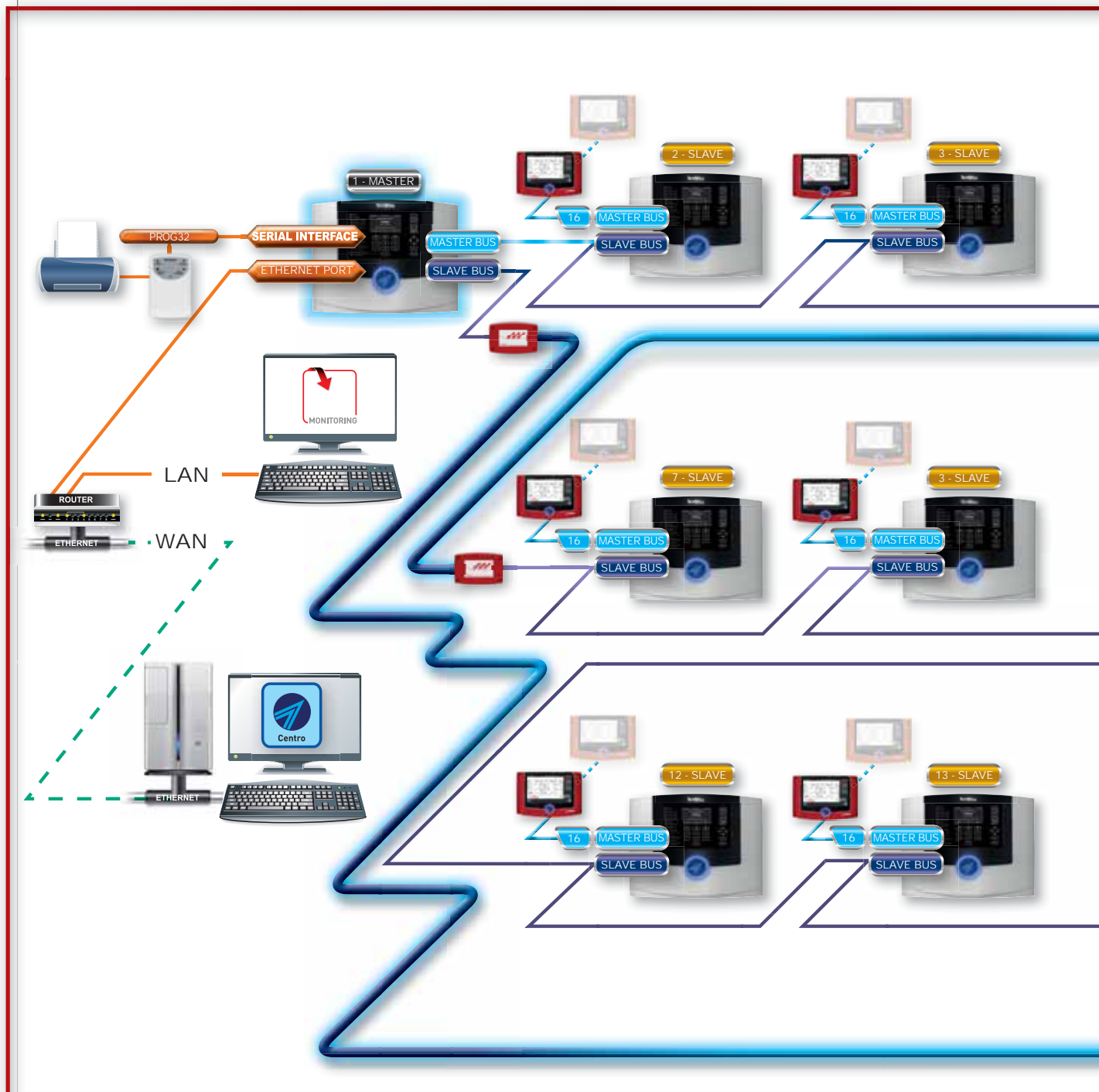



The system can consist of multiple control units, up to a maximum of 16 addressable units, networked through supervised BUS RS485 Fire-Bus.

The infrastructure of the network of control units can be realized with copper wires or optical fiber. The network hierarchy provides for a Master (main) control unit and up to 15 Slave control units.

The Master control unit has complete control over the Slave control units, all the information and alerts generated by the Slave control units are conveyed to the Master control unit.

The operation of the control units in network mode complies with the applicable standard EN 54-13.

Legislation restriction - The standard EN 54-2 Chapter 13.6 provides that, in case of failure, no more than 512 fire detection points and/or manual alert points and their mandatory functions are affected.

Therefore, to maintain compliance with the standard EN 54-2 on each control unit, it is not possible to use more than 512 detection devices and/or manual alert points.

Therefore, the maximum number of detection points manageable by a network of Tecnofire control units is 8192 points (16 control units, each with 512 points).

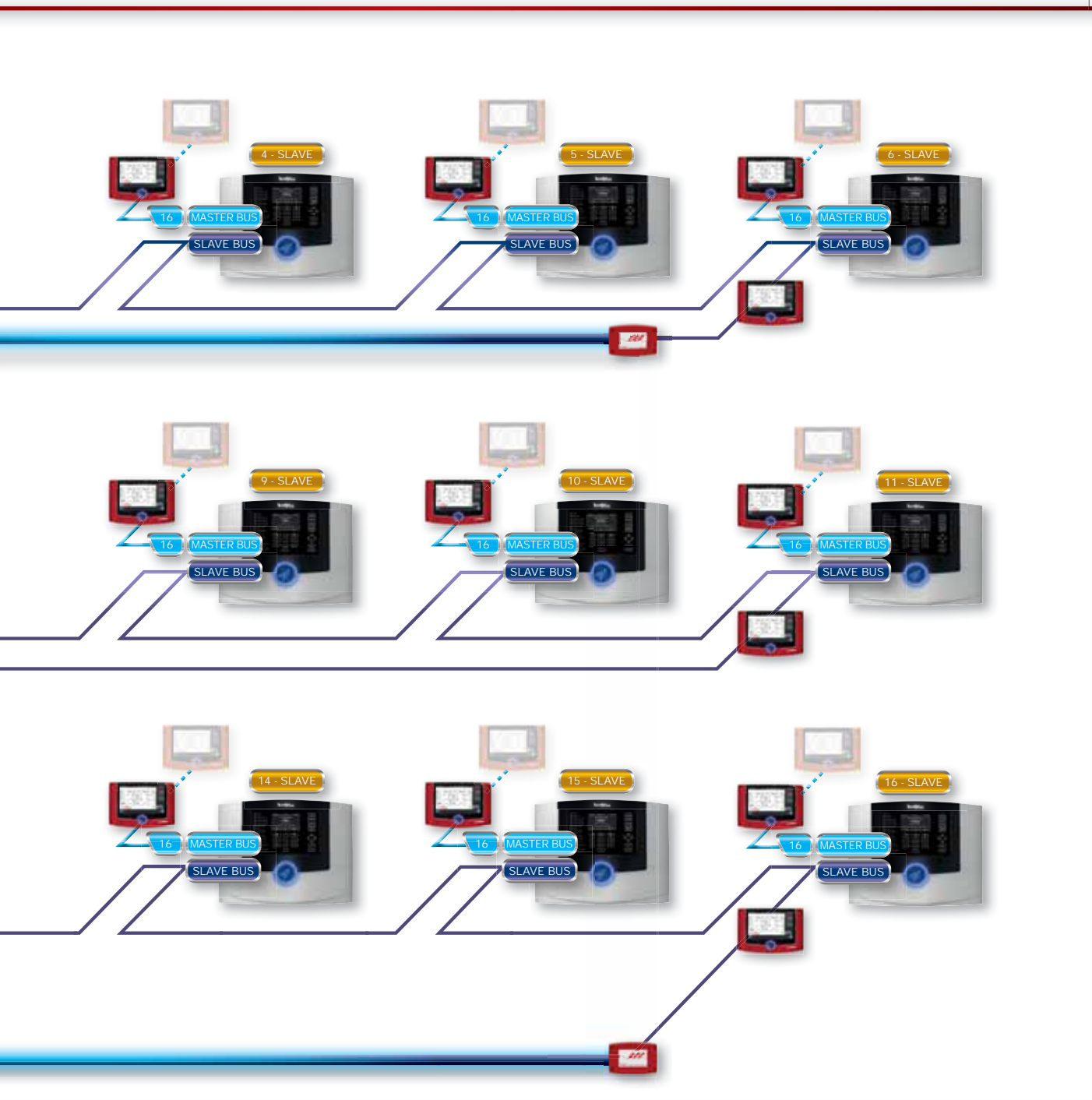

TFA4-1192 - Technical and functional specifications

Detectors Modules Zones	Total controllable detectors	796	System expandability	Expansions RS485 connection (max. 16 units)	TFT-7	
	Total detectors for each loop	199			TFT-7S	
	Total controllable modules	396			Telephone dialer	
	Total modules for each loop	99		Ethernet interface		
	Total controllable zones	300		Network of control units BUS RS485 connection	1 Master control unit	
	Virtual zones	100		Serial printer	15 Slave control units	
Signalling outputs	Specialised relays	2	Electrical specifications	CPU power requirements	200mA @ 24V DC	
	Programmable relays	3		Electrical outputs	Max. 50mA	
	Programmable open collectors	3		Loop power supply voltage	20V...27.6V DC	
	Controlled output for siren	1		BUS RS485 voltage supply		
	Reset Output	1		Siren voltage supply		
Control unit provisions	TFT True Color graphic display	480 x 272 pixel	Power supply	Modular power supply	Type A (switching flyback)	
	Voice synthesis	Customizable vocabulary		Supply voltage	230V AC +10 -15% 50Hz	
	Detection loops	4 Loops		Maximum current requirements	700mA AC	
	Serial BUS RS485	1 - Master BUS		Nominal values	5A @ 27.6V DC	
	Event memory capacity	8192		Maximum current deliverable	1 max. 5A	
Management modes	Access levels	4	Max ripple	≤150mV pp		
	Access codes	10	Battery protection	Fuse T-1,6A		
	Manned system mode	Programmable	Battery	Flammability class	V-2 or higher	
Communication protocols	Detection loops	FIRE-SPEED		Trip voltage	For Vbat <17,6V	
	BUS RS485	FIRE-BUS		Charge time (2 x 12V-12Ah)	100% in 24 hours	
IP node	Ethernet interface	Standard 803.2	Physical specifications	Environmental class	3K5 EN 60721-3-3:1995	
	Carrier	IP		Operating temperature	+5° C... +40° C	
	Communication channels	Local Server		10%...93% (non condensing))	Battery housing	2 x 12V/12Ah
		Remote Server			Protection degree	IP30
		Tecnoserver			Casing	Aluminum - Steel
		Call back			Dimensions (L x H x D)	441 x 347 x 149mm
	Communicators	8		Weight (without battery)	6.2Kg	
	IP addresses	16 (2 for each communicator)		Conformity	Control Unit	EN 54-2: 1997+A1: 2006
	Communicable events	15 (categories)			Power supply	EN 54-4: 1997+A2: 2006
	Communication protocols	5			Certification number	0051-CPR-0388
Encryption	AES 128 bit	Year of CE marking	14			
Event queue	64 items	Number of declaration of performance	002_TFA4-1192			
Automated controls	Formulas	400	Notified body	IMQ		
	Alarm plans	200				
	Time ranges	32				
	Calendar years	4 (programmable)				
	Server cyclic test	Programmable				

N.B. The declarations of conformity and performance are available on the website: www.tecnofiredetection.com