

DS-2TS03-15XF/W Handheld Observational Thermal Monocular



Hikvision DS-2TS03-15XF/W handheld observational thermal monocular is equipped with a 384 × 288 infrared detector and a 720 × 540 LCOS display. It supports functions of observation, highest temperature target tracking, distance measurement, Wi-Fi hot spot, and so on. The high-sensitivity built-in thermal detector provides you with clear view even in total darkness. The monocular is mainly applied to scenarios such as patrolling, law enforcement, searching and rescuing, drug enforcement, anti-smuggling, criminal seizing, hiking, travel, and hunting, etc.

Key Features

- 384 × 288 resolution, high sensitivity detector
- Adaptive AGC, DDE, 3D DNR, NETD less than 35 mk (@25°C), F#=1.0
- 720 × 540 resolution 0.2-inch LCOS display
- Built-in rechargeable lithium battery
- More than seven hours continuous running (with Wi-Fi hot spot function off)
- Wi-Fi hot spot
- Type-C Interface



Specification

Thermal Module	
Image Sensor	Vanadium Oxide Uncooled Focal Plane Arrays
Max. Resolution	384 × 288
Response Waveband	8μm to 14μm
NETD	less than 35 mk (@25°C), F#=1.0
Lens (Focal Length)	15 mm
IFOV	1.13 mrad
Field of View	24.6° × 18.5° (H × V)
Digital Zoom	1 ×, 2 ×, 4 ×
Aperture	F1.0
Magnification	0.6
Frame Rate	50 fps
Image Display	
Monitor	0.2 inch, LCOS, 720 × 540
FFC (Flat Field Correction)	Auto, Manual, External Correction
Palettes	Black Hot, White Hot, Red Hot, Fusion
Smart Function	
Highest Temperature Target Tracking	Yes
Wi-Fi Hot Spot	Yes
Standby Mode	Yes
System	
Storage	Built-in memory module (8 GB)
Record Video	On-board video recording
Capture Snapshot	Yes
Power Supply	
Battery Type	Lithium Battery
Battery Operating Time	More than seven hours continuous running (with Wi-Fi hot spot function off)
Battery Capacity Display	Yes
General	
Power	5 VDC/2 A, 1.5 W, Type-C Interface
Working Temperature	-20 °C to 55 °C (-4 °F to 131 °F)
Protection Level	IP67
Drop Test Height	1.5 m (4.92 feet)
Dimension	161 mm × 61 mm × 57 mm (6.34" × 2.40" × 2.24")
Weight	Approx. 270 g (0.60 lb)

Detection Range Table

* The table is only for reference, the performance may vary from camera to camera.

Wide Range Coverage

There is range limit for detecting, recognizing, and identifying human/vehicle targets.

Detection Range (Vehicles: 1.4 × 4.0 m)	Detection Range (Humans: 1.8 × 0.5 m)	Recognition Range (Vehicles: 1.4 × 4.0 m)	Recognition Range (Humans: 1.8 × 0.5 m)	Identification Range (Vehicles: 1.4 × 4.0 m)	Identification Range (Humans: 1.8 × 0.5 m)
1353 m	441 m	338 m	110 m	169 m	55 m

Available Model

DS-2TS03-15XF/W

Dimension

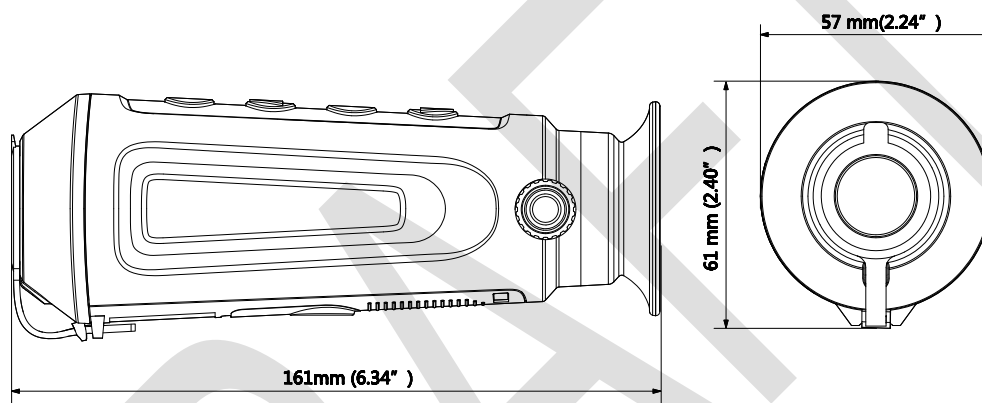

Distributed by

HIKVISION®**Headquarters**

No.555 Qianmo Road, Binjiang District,
Hangzhou 310051, China
T +86-571-8807-5998
overseasbusiness@hikvision.com

Hikvision USA
T +1-909-895-0400
sales.usa@hikvision.com

Hikvision Australia
T +61-2-8599-4233
salesau@hikvision.com

Hikvision India
T +91-22-28469900
sales@pramahikvision.com

Hikvision Canada
T +1-866-200-6690
sales.canada@hikvision.com

Hikvision Thailand
T +662-275-9949
sales.thailand@hikvision.com

Hikvision Europe
T +31-23-5542770
sales.eu@hikvision.com

Hikvision Italy
T +39-0438-6902
info.it@hikvision.com

Hikvision Brazil
T +55 11 3318-0050
Latam.support@hikvision.com

Hikvision Turkey
T +90 [216]521 7070- 7074
sales.tr@hikvision.com

Hikvision Malaysia
T +601-7652-2413
sales.my@hikvision.com

Hikvision UK & Ireland
T +01628-902140
sales.uk@hikvision.com

Hikvision South Africa
Tel: +27 (10) 0351172
sale.africa@hikvision.com

Hikvision France
T +33(0)1-85-330-450
info.fr@hikvision.com

Hikvision Kazakhstan
T +7-727-9730667
nikia.panfilov@hikvision.ru

Hikvision Vietnam
T +84-974270888
sales.vt@hikvision.com

Hikvision UAE
T +971-4-4432090
salesme@hikvision.com

Hikvision Singapore
T +65-6684-4718
sg@hikvision.com

Hikvision Spain
T +34-91-737-16-55
info.es@hikvision.com

Hikvision Tashkent
T +99-87-1238-9438
uzb@hikvision.ru

Hikvision Hong Kong
T +852-2151-1761
info.hk@hikvision.com

Hikvision Russia
T +7-495-669-67-99
saleru@hikvision.com

Hikvision Korea
T +82-(0)31-731-8817
sales.korea@hikvision.com

Hikvision Poland
T +48-22-460-01-50
info.pl@hikvision.com

Hikvision Indonesia
T +62-21-2933759
Sales.Indonesia@hikvision.com

Hikvision Colombia
sales.colombia@hikvision.com